

INTRODUCTION

The enclosed game is meant to serve as a participatory tool to help facilitate engagement with conflict-affected children and youth.

The game was originally designed to help young people articulate the risks (snakes) - as well as the

sources of support (ladders) - encountered upon exiting armed groups/forces. The game can also be used to facilitate discussions about vulnerabilities to recruitment and sources of resilience that help prevent armed group/force association.

These discussions can help provide a foundation for the design and implementation of prevention and reintegration programming that is responsive to the needs and realities of young people.

The game should only be used in contexts where consent has been obtained, confidentiality principles are affirmed by all facilitators and participants, and efforts to ensure the security and privacy of those involved have been taken.

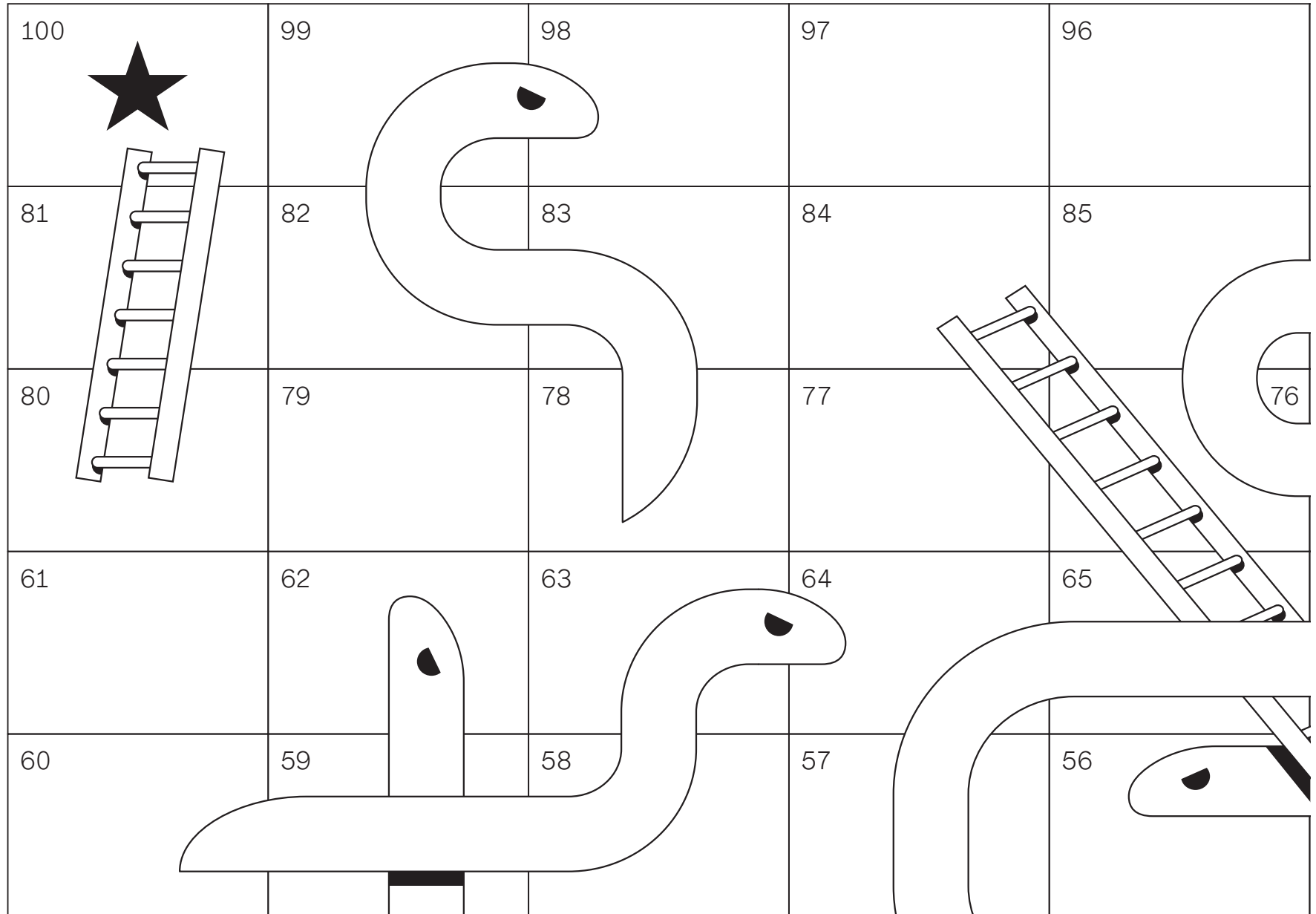

1. START

Each person puts their playing piece on the start space marked with an arrow. Each player rolls a dice, and the one with the highest number has the first turn.

2. STEPS

Each player rolls the dice in turn and moves their piece forward according to the number shown on the dice. For example, when someone rolls a 5, they move their piece forward 5 squares, following the numbers on the board.

If the player lands on the head of a snake, their piece has to slide down to the bottom of the snake and start from that square in the next round. (If their piece lands on the middle or bottom of the snake, they don't have to do anything, they stay in that square).

If the player lands at the base of a ladder, their piece can climb up to the top of it. (If they land on the middle or top of the ladder, however, they stay there). If the player rolls a 6, they can move their piece forward and then roll the dice again!

3. FINISH

The first player who reaches the highest space marked with a star completes the journey. They have to roll the exact number to get there. For example, when they are in space "98" and roll a 4, they cannot move forward but have to wait until they roll a 2.

95	94	93	92	91
86	87	88	89	90
75	74	73	72	71
66	67	68	69	70
55	54	53	52	51

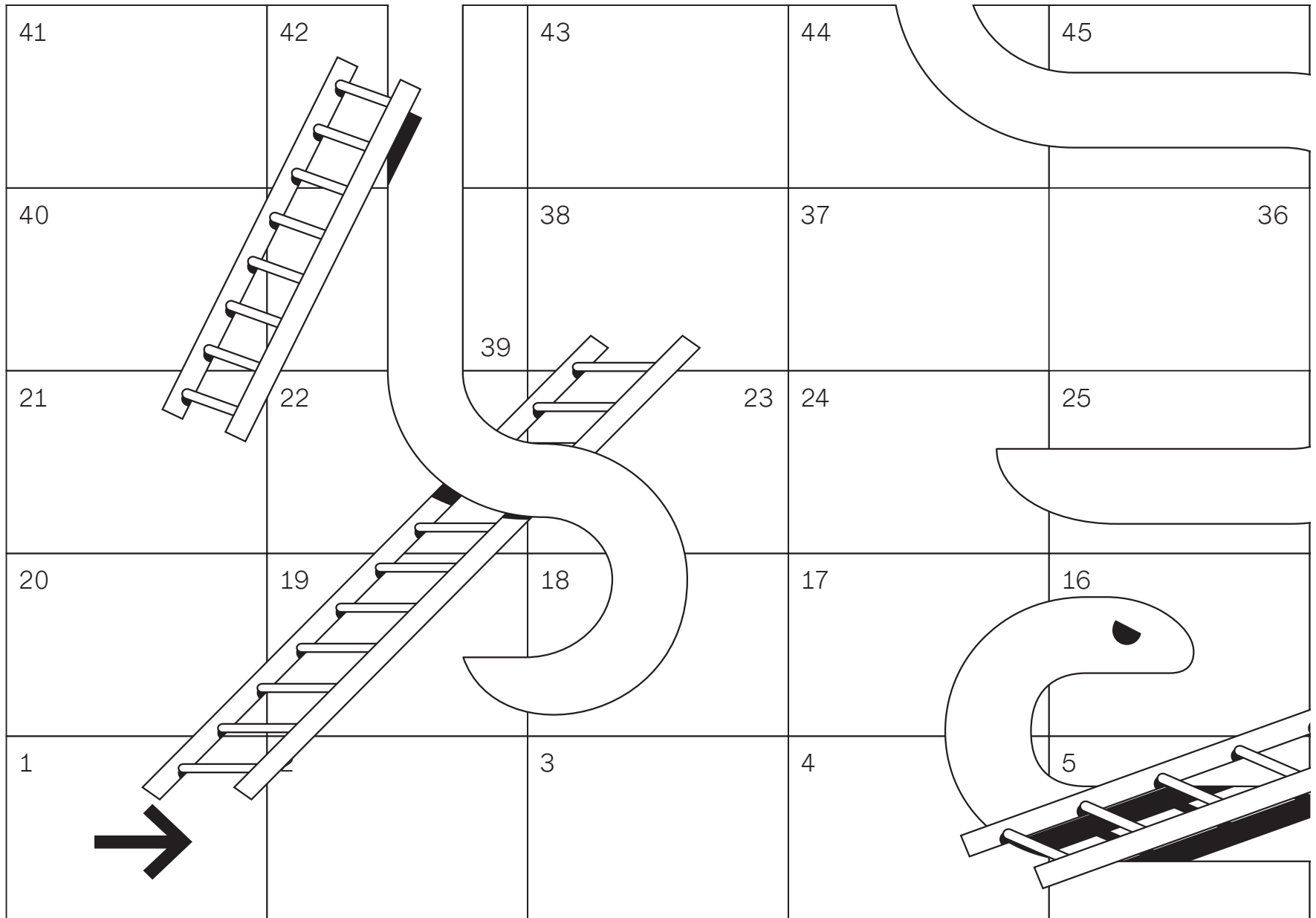

HIGH STAKES

Navigating Conflict Exits

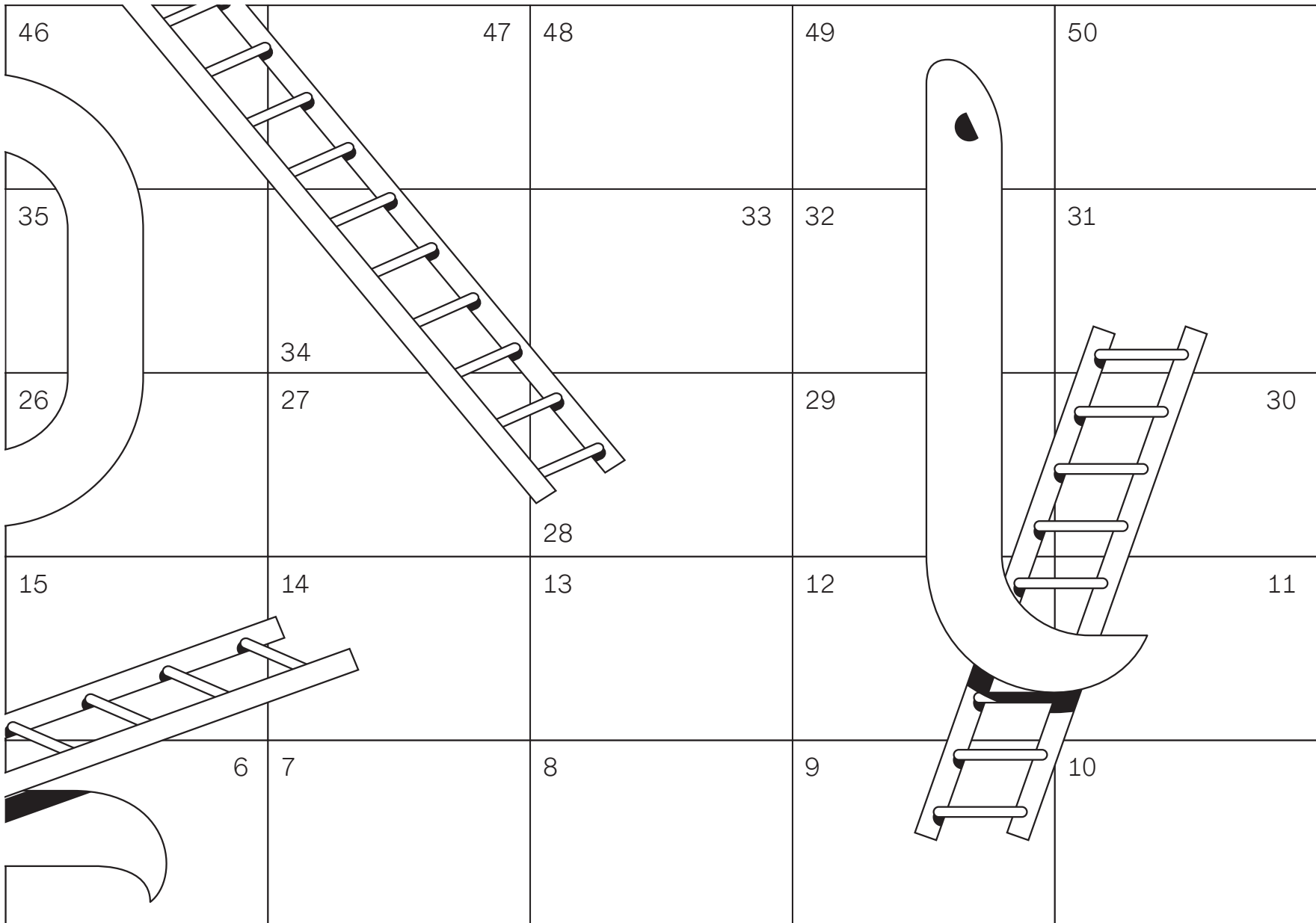

**UNITED NATIONS
UNIVERSITY**
Centre for Policy Research